



## Performance Evaluation of Energy Reduction of Light Shelf Applying Punching Plate

Choi, Yuchang\* · Lee, Heangwoo\*\* · Seo, Janghoo\*\*\* · Kim, Yongseong\*\*\*\*

\* Dept. of Architectural Design, Graduate School of Techno Design, Kookmin Univ., South Korea (uchangaa@hanmail.net)

\*\* Dept. of Architectural Design, Graduate School of Techno Design, Kookmin Univ., South Korea (moonup2001@nate.com)

\*\*\* School of Architecture / Dept. of Architectural Design, Graduate School of Techno Design, Kookmin Univ., South Korea (seojh@kookmin.ac.kr)

\*\*\*\* Corresponding Author, Dept. of Architectural Design, Graduate School of Techno Design, Kookmin Univ., South Korea (yongkim@kookmin.ac.kr)

### ABSTRACT

Various studies on lighting energy savings are conducted, given that lighting energy consumption accounts 23.5% of building energy consumption. Especially, external type light shelf's efficiency is acknowledged; however, its application is limited in Korea, where high rise building ratio is high, due to high wind pressure. This study delves into natural lighting system to cope with wind pressure, and proposes the punching plate-installed light shelf. This study actually draws lighting energy output, according to whether the punching plate is applied through the test-bed, and verifies the effectiveness of the punching plate-installed light shelf. The conclusion is presented below: First) The result of performance evaluation of light shelf with the punching plate in winter solstice showed that the awning area decreased as the opening ratio increased so that the indoor distributed illumination tended to increase, and  $-40^\circ$  which was advantageous for awning was determined as the proper angle. Second) The light shelf with the punching plate in spring/autumn equinox shows improved lighting according to the angle, and the appropriate angle of light shelf with the punching plate has increased to  $15^\circ$  and  $20^\circ$  according to the opening ratio in comparison to  $5^\circ$  which is the appropriate angle of light shelf with no punching plate due to the reflection area reduced by the reflecting plate with holes. Third) The result of performance evaluation of light shelf with the punching plate in summer solstice showed that the lighting performance tended to decrease as the opening ratio increased. 4) The light shelf with the punching plate incurs a 50% energy loss in comparison to the light shelf with no punching plate. However, its effectiveness has been proven in the aspects that it can bring a 50% energy saving in comparison to the case with no installation of light shelf and that it can be designed in response to wind pressure on the high floors.

### KEYWORD

Punching plate  
Vent Ratio  
Exterior Light Shelf  
Evaluation performance

### ACCEPTANCE INFO

Received September 12, 2014  
Final revision received October 6, 2014  
Accepted October 8, 2014

© 2014 KIEAE Journal

## 1. Introduction

### 1.1. Background and purpose of study

In Korea, energy consumption for buildings account for 24% of the country's overall energy consumption. Also, in turn, light energy consumption accounts for 22% of the total building energy consumption.<sup>1)</sup> Accordingly, need for research in and development of technology that can reduce consumption of light energy is continuously rising. Light shelf is one of the solutions developed to solve this problem. Light shelf is a natural lighting system that uses the reflection of natural light to provide lighting for buildings. With proven energy efficiency, light shelf is used in variety of places and there are currently many researches being done today. In particular, outdoor light shelf that is installed outside buildings turns out to exhibit superior light collection performance and, therefore, is being widely used.<sup>2)</sup>

However, according to 2014 Statistics Korea data, the share of

buildings with 6 stories and greater is 39.1% in Korea, which is very high. Moreover, there is an increasing number of ultra high-rise buildings with 50 stories or greater. They are becoming restrictions to installing light shelves consisting of flat reflector on high story floors where there is heavy wind pressure.

Furthermore, they will become a stumbling block to light shelf researches in Korea and market success. In this regards, researches on light shelves that can respond to heavy wind pressure created in high rise buildings are necessary.

In this research, we studied light collection and shade system that can respond to wind pressure and proposed punching plate-installed light shelf that can respond to heavy external wind pressure based on the results. The ultimate goal is to verify the effectiveness of light shelves by conducting test-bed performance test on the punching plate-installed light shelves proposed.

1.2. Method and scope of research

This research proposes a light shelf system that can withstand heavy external wind pressure in high rise buildings. Also, we developed and built a test bed system in order to perform tests to verify the effectiveness of the punching plate-installed light shelf system in terms of reducing energy use; and compare and analyze the punch plating light shelf to existing light shelves. This research will progress as follows.

First, studies on previous literatures were done on the concept of light shelf and related variables; light collection that accommodates external wind pressure and shade system; and theoretical consideration for illumination level, in that order. Second, in order to conduct performance assessment of punching plate-installed light shelf, width, height, angle and reflection rate of light shelf were set up and its vent ratio was set. Third, test beds were used to compare performance of punching plate-installed light shelf against existing light shelves to verify reduction in energy use.

2. Proposing the light shelf system that accommodates wind pressure and consideration for indoor illumination level to assess performance

2.1. Proposing the exterior light shelf that accommodates wind pressure in high story floors

1) Concept of light shelf and related variables

Light shelf, as shown in <Fig. 1>, is a natural light collecting system that can enhance quality of illumination in interior space while reducing use of light energy. It was invented to solve problems associated with glare or imbalance in illumination level

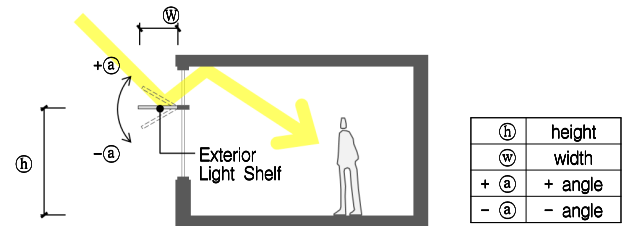

Fig. 1. Concept and variable of light Shelf







in interior space as a result of letting the natural light directly enter a room from outside. Instead, it stops natural light from directly entering the room and uses reflection to guide the light deeply penetrate the space, thus creating consistent distribution of illumination inside the room.

Factors that affect light collecting function of light shelf include its type, angle, height, raw material and width. The exterior type light shelf, although superior in light collecting performance, can easily be damaged from diverse environmental factors, which requires researches to solve the problem.

2) Proposing exterior type light shelf to accommodate wind pressure on high story floors

In this research, as shown in <Table 1>, we tried to develop a methodology based on cases based on exterior type shade and light collecting system that can accommodate wind pressure. The existing shade system employs a method that uses a wind sensor to open/close or fold or a method that uses casting net of wind opening. The method that uses a wind sensor to open/close or fold, when used in the high story floors of a building with high wind pressure, is expected to yield low efficiency in light collection. Therefore, we are proposing a light shelf based on the method that uses casting net instead. Since light shelf uses the light reflecting plate to guide light into a room, when a casting net is

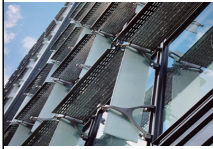
Table 1. Analysis of awning system cases responding to wind pressure

Wind pressure coping methods	Apply Case		Analysis of merits and demerits
Wind speed sensor open/close or collapse	 <p>Name: Kaeser Compressor Applied systems: Blind</p>	 <p>Name: luxaflex - horiso Applied systems: Blind</p>	<ul style="list-style-type: none"> <li>- Minimization of damage caused by wind pressure through active opening and shutting or folding according to wind pressure</li> <li>- Awning and lighting efficiency goes down with awning and lighting system closed or folded according to wind pressure.</li> </ul>
	 <p>Name: Seoul Eun-pyeong Post Office Applied systems: Blind</p>	 <p>Name: Gimcheon Supply &amp; Construction Office of Korea Post Applied systems: Blind</p>	
Wind holes apply	 <p>Name: AIG Europe Headquarters Applied systems: Louver</p>	 <p>Name: LS Tower Applied systems: Louver</p>	<ul style="list-style-type: none"> <li>- Minimization of wind pressure effect by punching application</li> <li>- Awning and lighting efficiency reduction by punching application</li> </ul>

used on the light reflecting plate, it is possible that shading or light collection performance could decline. This could cause problems and therefore it is crucial to assess performance carefully.

3) Consideration for design criteria for punching plate-installed light shelf

In this research, in order to prevent light shelf's reflecting plate from being damaged by wind pressure, we used the concept of punch metal where it is used to punch holes of various shapes on a thin plate. Punching standard used in punching metal-related industries is as shown in <Table 2>. The observed punching sizes were later used to set vent ratio to assess performance. Moreover, in this research, performance assessment was done only on general circular shape holes among various shapes of punching holes.

Table 2. Standard of punching plate

<b>Circular-type hole (Diameter 4mm)</b>	<b>Circular-type hole (Diameter 6mm)</b>
<b>Circular-type hole (Diameter 8mm)</b>	<b>Circular-type hole (Diameter 10mm)</b>

2.2. Standard for interior space illumination

Maintaining consistent illumination level in interior space is crucial in terms of providing pleasant environment for residents as well as reducing use of light energy. In Korea, standard for interior space illumination is quantitatively described in KS A 3011.

Illumination standard, as shown in <Table 3>, has established the minimum permissible illumination, standard illumination and the maximum permissible illumination according to activity types. In this research, we set 400lx, standard illumination level for ordinary works, as criteria for illumination control in order to analyze light collection performance of light shelf.

Table 3. KS recommended levels of illumination

Type of activity	Scope[lx]		
	Min.	Ave.	Max.
Visual Performance according to the degree of high-brightness	150	200	300
Visual Performance according to the degree of general-brightness	300	400	600
Visual Performance according to the degree of low-brightness	600	1000	1500

3. Performance assessment for punching plate-installed life shelf

3.1. Setting up environment for punching plate-installed light shelf performance assessment

1) Overview of performance assessment test bed

We have developed and built test beds in order to assess performance of punching plate-installed light shelf. Test beds shown in <Table 4> and <Fig. 2> are the overview and landscape of the test beds. The artificial solar panel of the test beds can control height and angles to set height as well as the amount of light to control external illumination level.

Table 4. Overview of Test-bed

Overview of Test-bed	
Room Size	4.9m(W) × 6.6m(D) × 2.5m(H)
Windows Size	1.76m(W) × 1.76m(H)
Directions	South aspect
Overview of Chamber model	
Chamber Size	4.5m(W) × 2.7m(D) × 4.6m(H)
Artificial Solar Probe device	2.08m(W) × 2.8m(H)

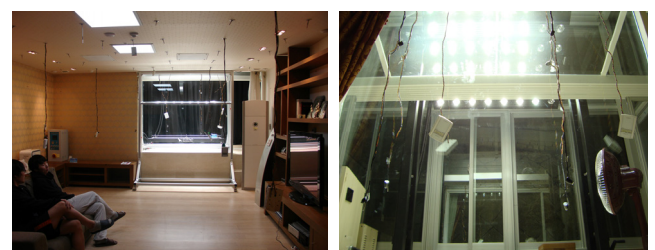

Fig. 2. View of Test-bed

2) Setting light shelf variables and punching plate-installed light shelf vent ratio

Variables for light shelf set up for this research are as shown in <Table 5>. The width of exterior type light shelf was set at 0.30m, suggested as ideal by previous researches on light shelf performance assessment. The height of light shelf was set at 1.8m from the ground based on consideration for eye level of residents and performance assessment results.

Table 5. Variables of Light Shelf

<b>Width</b>	0.3m	
<b>Height</b>	1800mm(from flat)	
<b>Reflexibility</b>	specular reflection film (reflexibility 85%)	
<b>Meridian transit altitude</b>	winter	76.5°
	Spring & autumn	53°
	Summer	29.5°
<b>Angle range</b>	-40° ~ 40° (5° intervals)	

The size of punch hole for punching plate light shelf set for this research was based on the standard size used by punching metal related industry discussed in the previous page. The formula for calculating vent ratio of circular punch hole is shown in <Fig. 3>. The vent ratio based on diameter of punched circles is shown in <Table 6>.

Table 6. vent ratio according to the Diameter of circular-type hole

Diameter of circular-type hole(mm)	4mm	6mm	8mm	10mm
Vent Ratio	29.55%	32.58%	34.27%	35.35%

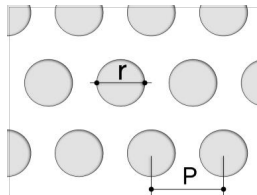

$$\text{Vent Ratio} = \frac{90.5 \times r^2}{P^2}$$

Fig. 3. Calculation method of vent ratio

### 3.2. Performance assessment method for punching plate-installed light shelf

In order to verify the effectiveness of performance of punching plate-installed light shelf, its performance was compared to that of normal (punching plate NOT applied) light shelf in terms of light collection function as shown in <Fig. 4>. The following method was then used to evaluate performances.

First, interior illumination values were calculated based on light shelf performance assessment variables. Locations chosen for measuring illumination were based on interior space illumination analysis study. 3)As shown in <Fig. 5>, two illumination sensors were placed at 2.2m and 4.4m position, considering the size of space and based on light collection window. Also, the height of illumination measurement was 450mm from the ground based on consideration for working area. 4)Second, among the values for illumination sensors realized by light shelf variables, the light shelf angles that satisfy 400lx were derived based on KS illumination standard for brightness work. If the measured illumination is below 400lx, the angle closes to 400lx was chosen.

Third, 4 illumination sensors were placed on 4 separate zones in the test-bed and linked to lighting. Then, the amount of light electricity produced by using on/off switch at 400lx of illumination sensor values was obtained. In addition, in terms of the amount of light electricity, based on related researches<sup>5)</sup>, the exterior illumination level was set at 30,000lx, 50,000lx and 80,000lx for clear day summer and winter and solstice and spring and fall equinox. Each season was 15 days based on 1 hour directly south.

3) Ilsik Cho, *A Study on Daylight Estimate of Interior Space Using Light Shelf*, Chungnam University, Ph.D. dissertation

4) Youkeun Chung, *Evaluation of All-in-One Type Window-Door Light Shelf Performance in Light Collection*, Korea Ecology Environment Architecture Association Paper Collection

5) Standard Illumination Chart (KS A 3011)



Ⓐ Light Shelf which has not been applied Ⓑ Light Shelf which has been applied

Fig. 4. Light Shelf applying punching plate

<Fig. 6> is the cross-section of test-bed and chamber. Artificial solar light emission facility was built outside the test-bed. Artificial solar light emission facility adjusted the amount of light, height and angle of the lamp to simulate four seasons and the corresponding external environment according to the azimuth of the sun.

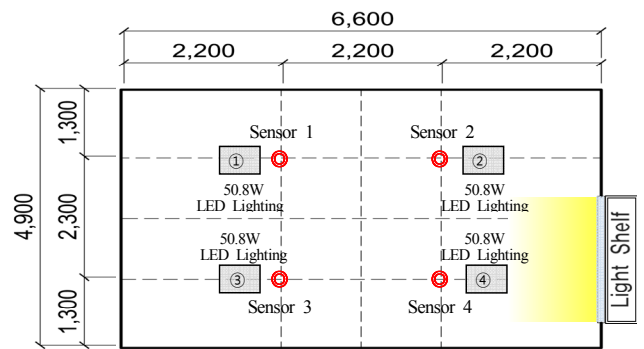

Fig. 5. Plane of Test-bed, Location of illuminance sensor

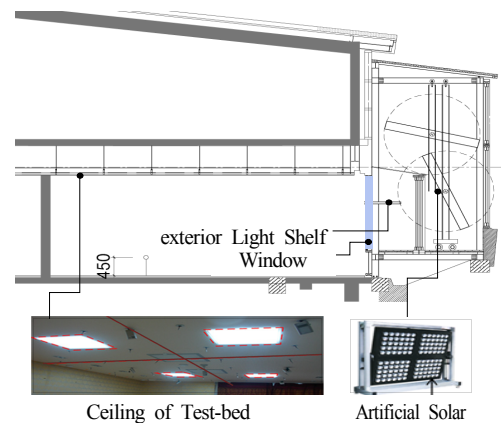

Fig. 6. Section of Test-bed

### 3.3. The result of performance evaluation of punching plate-installed light shelf

1) The result of performance evaluation of punching plate-installed light shelf during winter solstice

<Table 7> shows the distribution of illumination in interior space during solstice when light shelves are not installed; light shelves are installed without punching plate; and light shelves are

Table 7. Light Shelf performance evaluation applying punching plate during Winter solstice

Light Shelf not installed				Angle of Light Shelf	Light shelf with punching plate								
Sensor1	Sensor2	Sensor3	Sensor4		Vent Ratio : 29.55%				Vent Ratio : 32.58%				
769.52	946.40	1111.83	9646.10	-40	655.68	738.59	982.52	7174.82	665.16	767.18	980.66	7438.08	
				-35	662.57	761.00	985.10	7482.95	668.90	780.54	984.63	7665.95	
				-30	675.38	800.87	995.49	7642.59	679.58	835.83	991.98	7945.92	
				-25	690.95	847.83	1007.73	8150.73	692.18	872.94	1005.08	8390.61	
				-20	705.08	755.30	1021.40	8101.11	699.66	895.11	1018.44	8439.17	
				-15	715.50	908.57	1032.66	8276.99	728.04	91683.00	1030.32	8506.11	
				-10	733.23	945.99	1051.65	8367.21	732.12	946.11	1046.13	8533.23	
				-5	747.51	964.52	1080.00	8408.60	739.67	963.99	1057.83	8569.88	
				0	768.08	971.57	1111.10	8334.08	762.75	963.05	1090.53	8419.83	
				5	821.54	953.31	1182.33	8299.17	804.66	949.28	1144.40	8323.10	
				10	829.07	992.90	1218.89	9034.95	807.50	986.33	1179.35	9048.02	
				15	811.83	979.98	1181.55	10078.11	799.52	983.12	1159.11	9926.64	
				20	810.57	977.58	1181.66	10047.33	805.14	979.83	1151.15	9991.47	
				25	796.62	970.11	1158.45	10057.59	796.38	968.66	1135.58	10000.58	
				30	777.33	970.52	1136.61	10058.00	777.18	973.37	1115.61	10010.13	
				35	733.01	970.16	1088.16	9628.17	736.40	964.32	1065.33	9623.61	
				40	708.02	880.40	1031.73	8386.49	714.02	873.63	1015.11	8191.83	
Light shelf without punching plate				Angle of Light Shelf	Vent Ratio : 34.27%				Vent Ratio : 35.35%				
Sensor1	Sensor2	Sensor3	Sensor4		Sensor1	Sensor2	Sensor3	Sensor4	Sensor1	Sensor2	Sensor3	Sensor4	
-40	624.18	695.58	955.07	6273.93	-40	671.12	777.66	965.16	7526.58	670.34	785.04	960.11	7565.57
-35	628.08	723.89	963.66	7013.55	-35	672.38	800.42	964.11	7711.49	670.62	796.83	960.98	7730.27
-30	640.62	775.98	968.25	7269.42	-30	675.33	845.73	977.00	7932.03	683.16	848.57	971.00	8035.11
-25	665.00	829.58	990.33	7772.49	-25	690.02	840.66	979.44	8357.61	692.04	871.80	987.38	8424.32
-20	676.07	856.04	1006.55	7839.11	-20	700.38	901.58	997.58	8470.52	692.63	897.39	995.87	8523.00
-15	694.85	889.08	1031.70	7925.30	-15	706.62	917.15	1006.62	8495.63	699.33	908.73	990.03	8503.13
-10	722.51	946.56	1060.59	8041.35	-10	722.63	949.98	1022.33	8583.50	714.90	945.66	1010.13	8604.71
-5	746.49	972.80	1084.14	8135.70	-5	725.13	958.44	1028.58	8591.61	710.57	945.63	1025.33	8602.67
0	784.23	976.80	1136.90	8171.00	0	750.50	956.16	1067.90	8351.16	735.48	922.98	1031.57	8221.92
5	820.80	969.69	1204.62	8284.46	5	787.50	935.58	1102.91	8146.28	772.58	907.59	1105.49	8027.03
10	841.19	998.06	1253.28	9174.30	10	796.13	973.20	1128.48	8741.00	778.16	945.99	1110.02	8568.99
15	810.21	985.23	1200.11	10140.86	15	791.49	980.64	1121.78	9544.62	767.28	973.11	1109.63	9556.28
20	825.11	985.65	1253.25	10140.99	20	783.03	971.00	1103.66	9750.38	768.71	964.64	1100.81	9532.83
25	804.51	983.60	1189.07	10178.10	25	785.79	964.62	1092.83	9752.66	760.83	950.61	1095.50	9574.11
30	790.38	982.58	1159.62	10209.50	30	769.10	980.33	1145.10	9828.44	746.40	947.37	1060.85	9526.58
35	736.80	980.85	1110.33	9783.14	35	725.51	962.67	1028.94	9358.07	716.73	947.12	1020.00	9177.45
40	706.16	880.83	1040.55	8362.52	40	713.66	867.50	990.50	8067.12	705.50	864.50	977.61	7976.61

Table 8. Light shelf's proper angle of light shelf during Winter solstice

Light Shelf	Light shelf proper angle	
Without punching plate	-40°	
With punching plate (Vent Ratio)	29.55%	-40°
	32.58%	-40°
	34.27%	-40°
	35.35%	-40°

installed with punching plate. Distribution of interior space illumination is 400lx regardless of light shelf installation. Also, distribution of interior space illumination according to light shelf installation is declining vs when light shelves are not installed. This is because the amount of direct sunlight has declined due to shading produced by installation of light shelves. On the other hand, in case of punching plate-installed light shelves, interior space illumination tends to increase as vent rate increases. This is because the increase

Table 9. Power use amount for lighting according to proper angles

Light Shelf	Lighting energy consumption= illumination energy(lightON) × time × seasons(days)	
Light Shelf not installed	50.8w(1)×1hour×15(day) = 0kWh	
Without punching plate	50.8w(0)×1hour×15(day) = 0kWh	
With punching plate (Vent Ratio)	29.55%	50.8w(0)×1hour×15(day) = 0kWh
	32.58%	50.8w(0)×1hour×15(day) = 0kWh
	34.27%	50.8w(0)×1hour×15(day) = 0kWh
	35.35%	50.8w(0)×1hour×15(day) = 0kWh

in vent rate results in increase in the amount of natural light from outside. The proper angles of light shelves that satisfy 400lx set in this research are shown in <Table 9>. Electricity use for lighting when punching plate-installed light shelves are used do not show loss in light energy compared to the case when light shelves without punching plate installation are used or light shelves are not installed at all.



2) The result of performance evaluation of punching plate-installed light shelves during spring and fall equinox

<Table 10> shows the distribution of illumination in interior space during solstice when light shelves are not installed; light shelves are installed without punching plate; and light shelves are installed with punching plate. During spring and fall equinox, illumination level tends to increase according to increase in angles compared to the cases when light shelves are installed without

punching plate or light shelves are not installed. Also, in case of punching plate-installed light shelves, interior space illumination level tends to increase as vent ratio increases. This is because an increase in vent ratio increases the amount of natural light entering. The proper angles for punching plate-installed light shelves during spring and fall equinox requires higher angles compared to light shelves without punching plate installed. This means that punching holes are needed to induce natural light to penetrate the interior

Table 10. Light Shelf performance evaluation applying punching plate during Summer solstice

Light Shelf not installed				Angle of Light Shelf	Light shelf with punching plate							
Sensor1	Sensor2	Sensor3	Sensor4		Vent Ratio 29.55%				Vent Ratio 32.58%			
Sensor1	Sensor2	Sensor3	Sensor4	Sensor1	Sensor2	Sensor3	Sensor4	Sensor1	Sensor2	Sensor3	Sensor4	
210.56	513.76	115.76	1080.48	-40	160.52	412.48	68.48	1021.16	150.00	394.52	84.92	969.80
				-35	165.84	441.00	65.00	1045.80	163.48	421.00	107.92	993.44
				-30	168.64	467.00	61.88	1090.52	173.00	444.44	100.00	1029.00
				-25	171.56	445.44	64.56	1049.12	165.24	413.00	93.00	974.96
				-20	153.00	414.24	50.56	1001.48	160.92	400.00	101.00	945.00
				-15	151.00	428.56	52.88	1000.76	150.00	410.20	100.48	955.00
				-10	168.48	446.92	60.52	1005.80	160.56	410.00	101.40	960.00
				-5	181.40	484.56	69.00	1089.04	172.72	443.00	93.84	1000.44
				0	185.00	553.36	73.88	1203.56	190.56	488.64	120.92	1088.12
				5	220.88	589.00	85.00	1264.88	209.00	533.00	127.12	1150.56
				10	243.04	640.68	124.44	1409.56	228.44	568.44	125.44	1261.08
				15	265.44	724.44	161.36	1612.68	260.84	624.48	170.00	1400.00
				20	308.56	767.92	213.04	1724.56	264.48	649.36	190.00	1472.48
				25	325.00	760.56	283.12	1702.56	285.00	629.36	230.00	1470.00
				30	345.12	681.24	348.56	1563.12	310.00	582.20	312.60	1353.40
				35	320.44	585.12	374.60	1244.40	305.00	505.00	305.44	1110.00
				40	311.12	602.96	305.44	1442.60	304.56	500.96	292.48	1225.00

Angle of Light Shelf	Light shelf without punching plate				Angle of Light Shelf	Vent Ratio 34.27%				Vent Ratio 35.35%			
	Sensor1	Sensor2	Sensor3	Sensor4		Sensor1	Sensor2	Sensor3	Sensor4	Sensor1	Sensor2	Sensor3	Sensor4
-40	161.80	392.52	45.84	951.12	-40	145.84	428.80	68.04	1020.04	187.12	434.84	62.84	1012.48
-35	173.44	404.12	52.48	982.68	-35	164.92	433.84	74.24	1073.04	190.24	446.60	74.44	1033.16
-30	184.56	440.48	83.12	1045.68	-30	167.00	449.00	85.44	1060.88	203.64	448.88	85.20	1053.44
-25	191.84	422.64	65.32	981.36	-25	160.60	443.40	52.88	1042.72	185.04	463.64	70.76	1033.20
-20	168.41	373.80	54.24	921.92	-20	153.44	424.44	63.12	1009.20	174.60	427.00	65.76	994.96
-15	155.12	388.92	60.48	924.48	-15	152.44	428.04	69.96	995.08	171.76	429.36	69.32	1002.20
-10	169.32	409.76	65.32	949.88	-10	161.00	441.44	73.32	1021.52	170.84	433.00	80.80	1014.56
-5	181.80	440.52	75.12	1014.69	-5	171.84	453.16	72.24	1053.72	180.00	474.96	83.76	1049.52
0	205.36	525.80	93.76	1148.84	0	188.56	502.56	87.52	1132.92	193.12	494.64	84.88	1148.56
5	243.12	588.52	128.52	1208.92	5	190.24	540.28	105.24	1222.76	207.00	524.32	110.04	1170.08
10	268.60	683.56	174.64	1401.12	10	212.88	600.88	121.20	1320.88	229.36	571.52	110.40	1247.88
15	300.92	734.36	188.48	1611.00	15	232.68	633.28	160.68	1455.12	243.28	592.16	142.84	1369.76
20	326.60	787.04	245.32	1733.00	20	266.68	664.68	202.36	1534.56	268.28	621.36	189.32	1432.80
25	359.12	720.48	326.24	1712.88	25	281.00	668.00	244.80	1521.88	285.84	621.76	211.96	1424.28
30	370.60	675.12	431.12	1500.08	30	308.68	620.68	292.88	1425.44	305.32	574.44	281.12	1345.32
35	363.12	565.80	404.44	1186.96	35	292.56	547.92	288.56	1180.12	302.96	534.92	285.36	1150.84
40	314.12	603.04	407.12	1351.64	40	320.88	540.88	308.88	1200.36	288.84	528.28	248.40	1228.24

: This indicates lower than 400lx

Table 11. Light shelf's proper angle of light shelf during Spring & autumn

Light Shelf	Light shelf proper angle	
Without punching plate	5°	
With punching plate (Vent Ratio)	29.55%	15°
	32.58%	15°
	34.27%	15°
	35.35%	20°

Table 12. Power use amount for lighting according to proper angles

Light Shelf	Lighting energy consumption= illumination energy(lightON) × time × seasons(days)
Light Shelf not installed	50.8w(1)×1hour×30(day) = 1.524kWh
Without punching plate	50.8w(0)×1hour×30(day) = 0kWh
With punching plate (Vent Ratio)	29.55% 50.8w(0)×1hour×30(day) = 0kWh
	32.58% 50.8w(0)×1hour×30(day) = 0kWh
	34.27% 50.8w(0)×1hour×30(day) = 0kWh
	35.35% 50.8w(0)×1hour×30(day) = 0kWh

space deeply in order to enhance light collection function. <Table 11> shows proper angles for light shelves that satisfy 400lx requirement set in this research. The amount of electricity used for illumination derived by the proper angles are shown in <Table 12>.

It is possible to reduce energy use when punching plate-installed light shelves are intalled as compared to when light shelves without punching plate are installed or light shelves are not installed at all.

3) The result of performance evaluation of punching plate-installed light shelves during summer solstice

<Table 13> shows the distribution of interior space illumination in each case of non-installation of light shelves; installation of light shelves with punching plate; and installation of light shelves

without punching plate during summer solstice. The proper angles of light shelves that satisfy 400lx set in this research are shown in <Table 14>. During summer solstice, punching plate-installed light shelves tend to show low interior space illumination distribution compared to other cases. However, enhancements are realized according to the angle of light shelves. As shown in <Table 15>, calculation of illumination electricity use according to light shelves angles shows that, while punching plate-installed light shelves show energy reduction compared to when light shelves are not installed, the situation is not favorable when compared to the case of light shelves not installed. This seems to be the result of performance reduction in light shelves due to punching hole plate. However, as mentioned earlier, punching plate-installed light

Table 13. Light Shelf performance evaluation applying punching plate during Spring & autumn

Light Shelf not installed				Angle of Light Shelf	Light shelf with punching plate								
Sensor1	Sensor2	Sensor3	Sensor4		Vent Ratio 29.55%				Vent Ratio 32.58%				
Sensor1	Sensor2	Sensor3	Sensor4	Sensor1	Sensor2	Sensor3	Sensor4	Sensor1	Sensor2	Sensor3	Sensor4		
420.75	694.35	357.28	1600.15	-40	401.30	1031.20	171.20	2552.90	375.00	986.30	212.30	2424.50	
				-35	414.60	1102.50	162.50	2614.50	408.70	1052.50	269.80	2483.60	
				-30	421.60	1167.50	154.70	2726.30	432.50	1111.10	250.00	2572.50	
				-25	428.90	1113.60	161.40	2622.80	413.10	1032.50	232.50	2437.40	
				-20	382.50	1035.60	126.40	2503.70	402.30	1000.00	252.50	2362.50	
				-15	377.50	1071.40	132.20	2501.90	375.00	1025.50	251.20	2387.50	
				-10	421.20	1117.30	151.30	2514.50	401.40	1025.00	253.50	2400.00	
				-5	453.50	1211.40	172.50	2722.60	431.80	1107.50	234.60	2501.10	
				0	462.50	1383.40	184.70	3008.90	476.40	1221.60	302.30	2720.30	
				5	552.20	1472.50	212.50	3162.20	522.50	1332.50	317.80	2876.40	
				10	607.60	1601.70	311.10	3523.90	571.10	1421.10	313.60	3152.70	
				15	663.60	1811.10	403.40	4031.70	652.10	1561.20	425.00	3500.00	
				20	771.40	1919.80	532.60	4311.40	661.20	1623.40	475.00	3681.20	
				25	812.50	1901.40	707.80	4256.40	712.50	1573.40	575.00	3675.00	
				30	862.80	1703.10	871.40	3907.80	775.00	1455.50	781.50	3383.50	
				35	801.10	1462.80	936.50	3111.00	762.50	1262.50	763.60	2775.00	
				40	777.80	1507.40	763.60	3606.50	761.40	1252.40	731.20	3062.50	
Angle of Light Shelf	Light shelf without punching plate				Angle of Light Shelf	Vent Ratio 34.27%				Vent Ratio 35.35%			
Sensor1	Sensor2	Sensor3	Sensor4	Sensor1		Sensor2	Sensor3	Sensor4	Sensor1	Sensor2	Sensor3	Sensor4	
-40	388.63	646.65	337.78	1620.30	-40	364.60	1072.00	170.10	2550.10	467.80	1087.10	157.10	2531.20
-35	388.33	643.20	333.40	1614.40	-35	412.30	1084.60	185.60	2682.60	475.60	1116.50	186.10	2582.90
-30	383.20	631.95	329.55	1580.20	-30	417.50	1122.50	213.60	2652.20	509.10	1122.20	213.00	2633.60
-25	376.90	625.35	330.35	1569.78	-25	401.50	1108.50	132.20	2606.80	462.60	1159.10	176.90	2583.00
-20	382.93	640.05	329.13	1583.33	-20	383.60	1061.10	157.80	2523.00	436.50	1067.50	164.40	2487.40
-15	395.20	643.35	325.83	1619.38	-15	381.10	1070.10	174.90	2487.70	429.40	1073.40	173.30	2505.50
-10	408.30	684.78	346.88	1669.28	-10	402.50	1103.60	183.30	2553.80	427.10	1082.50	202.00	2536.40
-5	428.28	719.43	356.53	1717.73	-5	429.60	1132.90	180.60	2634.30	450.00	1187.40	209.40	2623.80
0	445.10	758.80	377.73	1818.48	0	471.40	1256.40	218.80	2832.30	482.80	1236.60	212.20	2871.40
5	452.53	790.48	403.78	1912.55	5	475.60	1350.70	263.10	3056.90	517.50	1310.80	275.10	2925.20
10	482.35	808.20	427.55	1971.78	10	532.20	1502.20	303.00	3302.20	573.40	1428.80	276.00	3119.70
15	500.58	818.00	446.88	2000.55	15	581.70	1583.20	401.70	3637.80	608.20	1480.40	357.10	3424.40
20	525.53	803.33	525.80	1980.20	20	666.70	1661.70	505.90	3836.40	670.70	1553.40	473.30	3582.00
25	527.50	787.68	551.98	1901.80	25	702.50	1670.00	612.00	3804.70	714.60	1554.40	529.90	3560.70
30	504.68	744.75	529.35	1787.78	30	771.70	1551.70	732.20	3563.60	763.30	1436.10	702.80	3363.30
35	490.28	732.45	491.30	1915.63	35	731.40	1369.80	721.40	2950.30	757.40	1337.30	713.40	2877.10
40	484.55	757.70	440.55	1982.93	40	802.20	1352.20	772.20	3000.90	722.10	1320.70	621.00	3070.60

■ : This indicates lower than 400lx

shelves could be viewed as natural light collection system designed to accommodate wind pressure in high story floors. It is possible to conclude that it is effective in a sense that energy reduction is possible in comparison to the case of light shelves not installed.

Table 14. light shelf's proper angle of light shelf during Summer solstice

Light Shelf	Light shelf proper angle	
Without punching plate	35°	
With punching plate (Vent Ratio)	29.55%	30°
	32.58%	30°
	34.27%	30°
	35.35%	30°

Table 15. Power use mount for lighting according to proper angles

Light Shelf	Lighting energy consumption= illumination energy(lightON) × time × seasons(days)
Light Shelf not installed	50.8w(2)×1hour×15(day) = 1.524kWh
Without punching plate	50.8w(1)×1hour×15(day) = 0.762kWh
With punching plate (Vent Ratio)	29.55% 50.8w(2)×1hour×15(day) = 1.524kWh
	32.58% 50.8w(2)×1hour×15(day) = 1.524kWh
	34.27% 50.8w(2)×1hour×15(day) = 1.524kWh
	35.35% 50.8w(2)×1hour×15(day) = 1.524kWh

4) Discussion on performance evaluation of punching plate-installed light shelves

As shown in <Fig. 7>, consumption of electric power for illumination when punching plate-installed light shelves are installed is calculated to be 1.524kWh, 1 hour per day facing directly south for 60 days during summer/winter solstice and spring/fall equinox regardless of vent ratio. It is showing 50% reduction in illumination energy compared to the case when light shelves are not installed. Also, it is showing 50% loss in illumination energy compared to the case of punching plate-installed light shelves. This is probably due to decrease in amount of reflected light by punching holes of the light shelf's reflecting plate. However, punching plate-installed light shelves are effective in that it can be designed to accommodate heavy wind

pressure in high story floors and bring reduction in illumination energy compared to the case when light shelves are not installed. Also, reduction in illumination energy according to vent ratio set in this research turned out to be the same, which makes us believe that this is the range that can be used when designing punching plate-installed light shelves. However, distribution of interior space illumination according to vent ratio turned out to vary. Therefore, difference in vent ratio must be considered when applying illumination control such as dimming.

4. Conclusion

In this research, we proposed using punching plate-installed light shelf in order to accommodate wind pressure. Then, performance evaluation was conducted to verify its effectiveness. The conclusion is as follows.

First, in this research, we examined a natural light collection system that can withstand heavy wind pressure in high story buildings. We proposed using punching plate-installed light shelves. Second, the result of performance evaluation of punching plate-installed light shelves during winter solstice showed that illumination distribution for interior spacetends to increase as vent ratio increased and shading area declined. The proper angle favorable for shading was estimated to be -40°. In addition, compared to light shelves without punching plate, unnecessary induction of natural lights is being done, which should be considering during design process.

Third, punching plate-installed light shelves during spring and fall equinox are showing enhancement in light collection according to different angles. Compared to the proper angle of 5 ° for light shelves without punching plate, due to decrease in reflection area of the punching plate, the proper angle of punching plate-installed light shelves are increasing to 15 ° and 20 ° according to vent ratio.

Fourth, the result of performance evaluation of punching plate-installed light shelves during summer solstice shows that light collection function tends to decline according to increase in vent ratio. It is also showing enhanced interior space illumination distribution compared to the cae of light shelves without punching plate installed.

Fifth, in the case of punching plate-installed light shelves, illumination energy is showing 50% energy loss compared to the light shelves without punching plate installed. However, it is showing 50% enhancement in illumination energy reduction compared to the case of light shelves not installed. It has proven its effectiveness in that it can be designed to withstand wind pressure in high story floors.

Although we proposed the light shelf that can be designed to withstand wind pressure in high-rise buildings, it has a limitation in

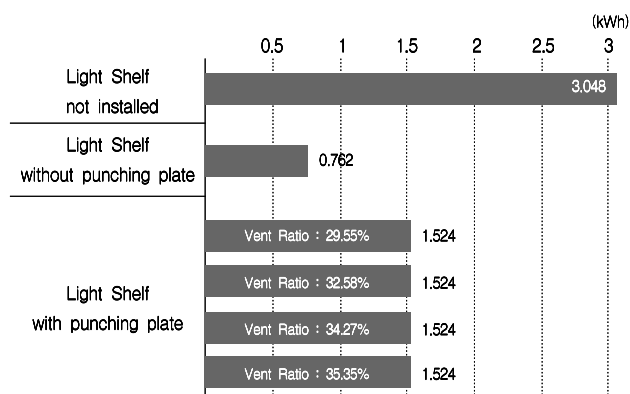

Fig. 7. Consumption of electric power according to types of Light Shelf



that the width of light shelf was restricted and the wind tunnel test was not performed. Also, the study focused exclusively on performance evaluation. In the future, it is necessary to conduct performance evaluation according to width and vent ratio of light shelves as well as a wind tunnel test according to vent ratio. In addition, economic analysis must be performed. Finally, energy use rate according to vent ratio appears to be same because only a simple on/off light control method was used. Therefore, it is recommended that performance evaluation be performed according to dimming light control method.

## References

- [1] Kim Jiyeon, Hong Seonghui, Park Hyosun, Seo Seungjik, Study on the Application of BIPV for saving the Lighting Energy in High-rise Building, KSES 207 Spring Annual Conference, 2007.04)
- [2] Lee Hyeonu, Lee Sinae, The Improvement of Uniformity Ratio for Luminous Environment Using Horizontal Lightshelf in an Office Building. Korean Journal of the living environment, Vol.18, No.1, 2011.02)
- [3] Punching metal manufacturer <http://www.sitagong.com/>
- [4] Punching metal manufacturer <http://gspunch.co.kr/>
- [5] Lee Haengwoo, Kim Deoksu, Kim Yongseong, Simulation Study on the Performance Evaluation of Light-shelf focused on the Depth of Space and the Dimensions and Angles of Light-shelf, Journal of the Architectural Institute of Korea Planning&Design, Vol.29, No.3, 2013.03)
- [6] Jung Yugeun, Daylighting Performance Evaluation of window Integrated Light Shelf System. Journal of the Korean Institute of Educational Architecture and Environment, Vol.7, No.5, 2013.03)
- [7] Seong Kyung Back, Seung Hoon Lee, A Study on Lighting Design and Illumination and Luminance of in Advanced type Control Room by the Standard of Ergonomics, Journal of the Ergonomics Society of Korea, Vol.27, No.2, 2008.05)
- [8] The Technical Development Status of Energy Convergence Building, Journal of the Architectural Institute of Korea Planning&Design, Vol.53, No.2 2009.02)
- [9] Analysis on the Indoor Daylight Performance having Light-shelf system, A Doctoral Dissertation, Graduate School Chungnam National University.)
- [10] Performance Assessment of Building EnvelopesII: LightShlef, RetroLux, KSES 2011 Spring Annual Conference, 2009)
- [11] Scale Model Experiment for Daylighting Performance by Lightshelf Types, Journal of the Korean Institute of Educational Architecture and Environment, Vol.5, No.2, 2005.11)
- [12] A Study on Light Shelf System Performance Evaluation Applying User Awareness and Dimming Control in Housing, Journal of the Architectural Institute of Korea Planning&Design, Vol.30, No.2, 2014)
- [13] An Fundamental Study on the Interactive System for Daylight Response Dimming System and Indoor Shading Systems, Proceeding of Annual Conference of the Architectural Institute of Korea Planning&Design, Vol.27, No.1, 2007)
- [14] An Analysis of Daylighting Performance of Light Shelf in Office Building, Journal of the Korean Institute of Illuminating and Electrical Installation Engineers, Vol.22, No.8, 2008)
- [15] Standard illumination table (KS A 3011)